

LUMOS MAXI TOWER

product set up instructions



Lumos Maxi Tower Setup Instructions



Items

- A:** 1x top screw;
- B:** 1x top;
- C:** 1x base;
- D:** 1x base screw;
- E:** 1x 624x2055mm graphic panel;
- F:** 1x mains transformer;
- G:** 1x charging transformer;
- H:** 1x charging adaptor;
- I:** 1x Lumos Maxi bottom upright;
- J:** 1x Lumos Maxi middle upright;
- K:** 1x Lumos Maxi top upright

PLEASE NOTE: The LED MagicBlue app is needed to use this product. The details to download this are on the base.

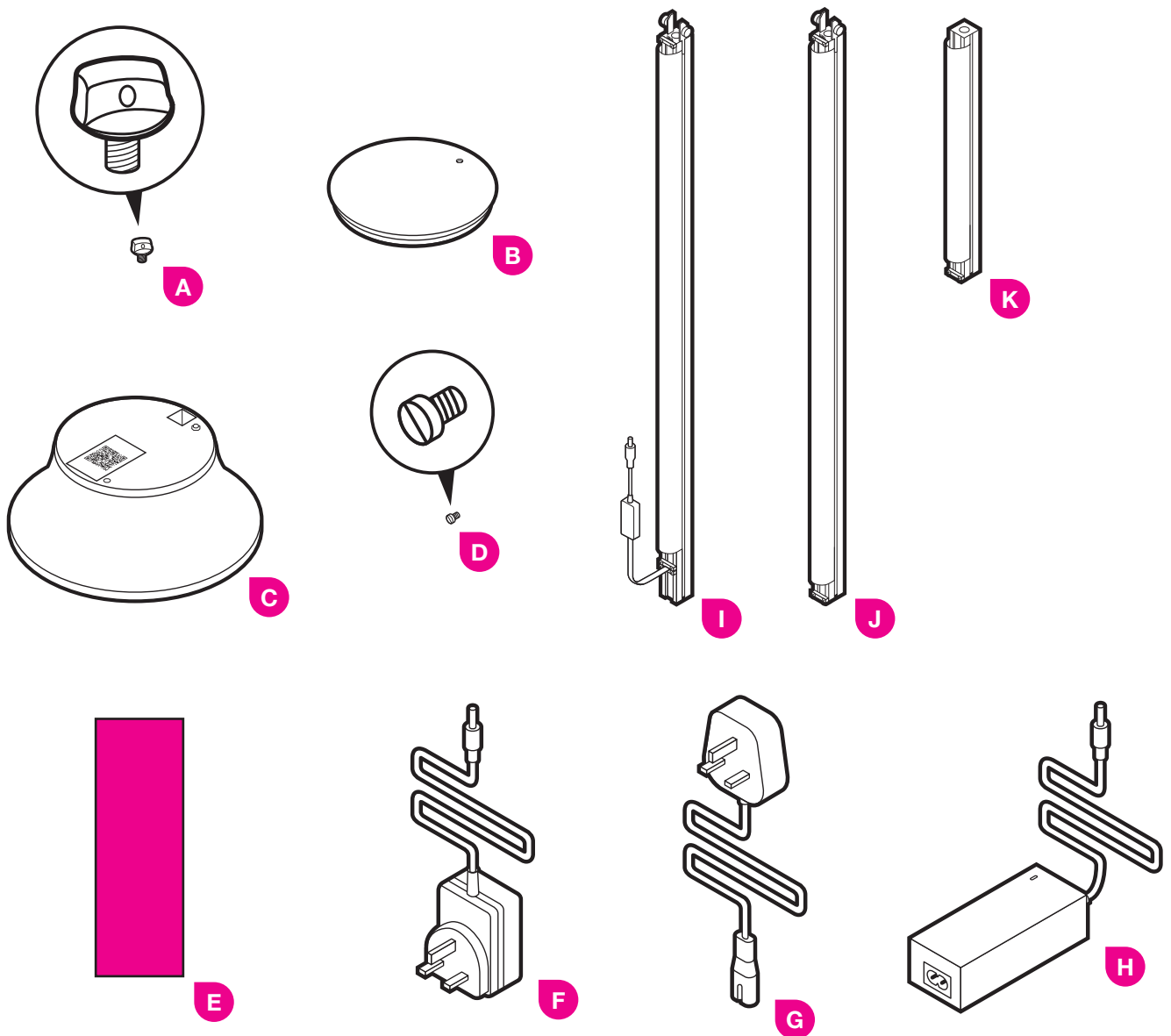

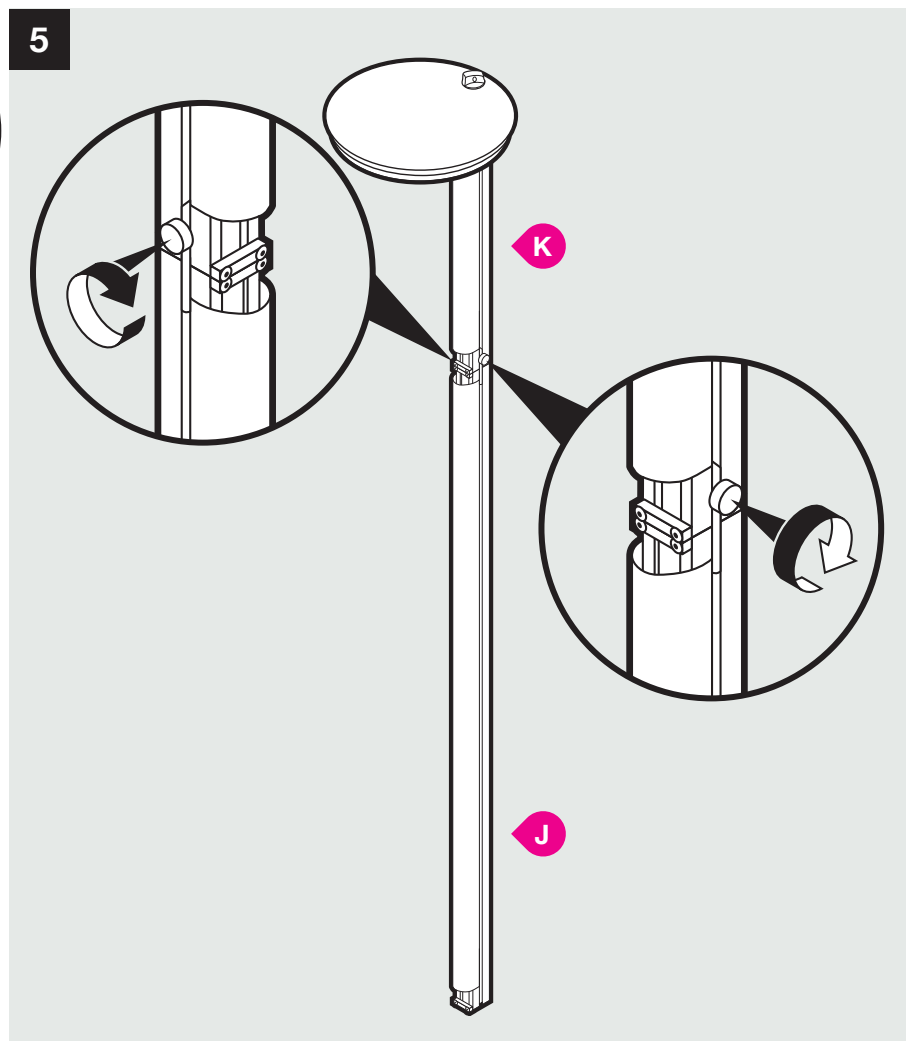
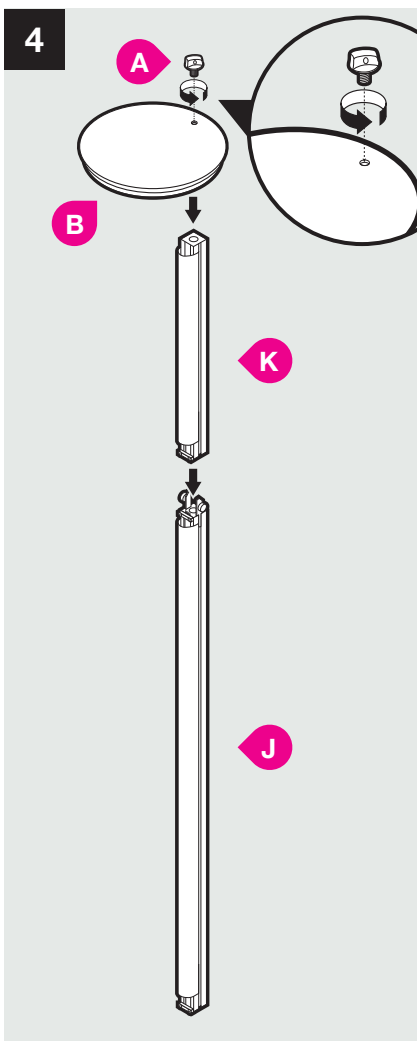
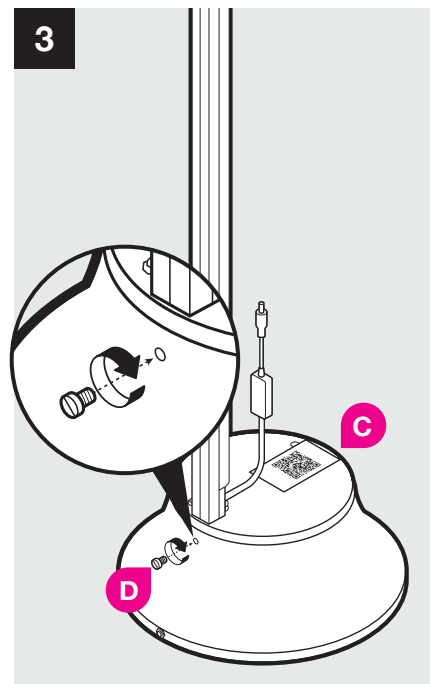
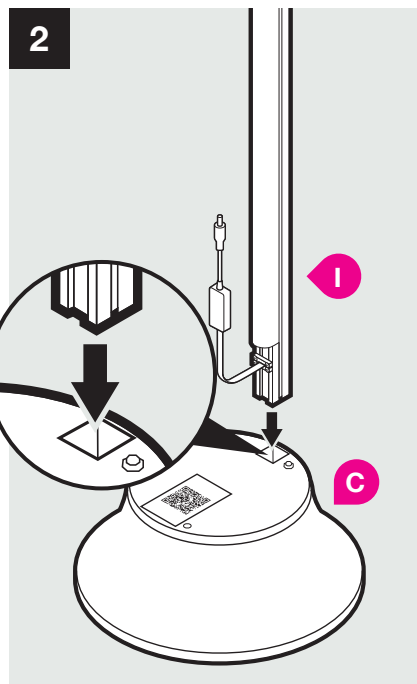
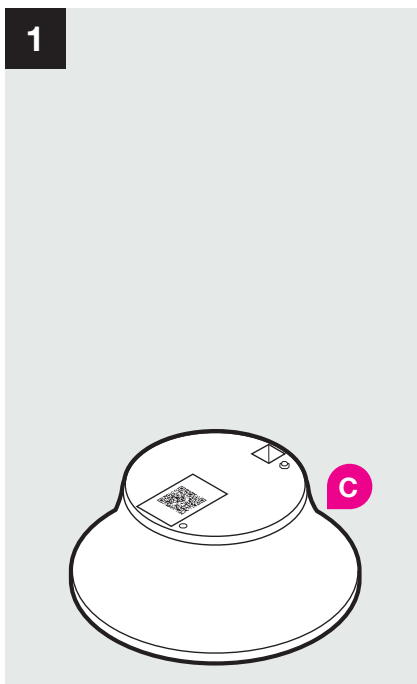

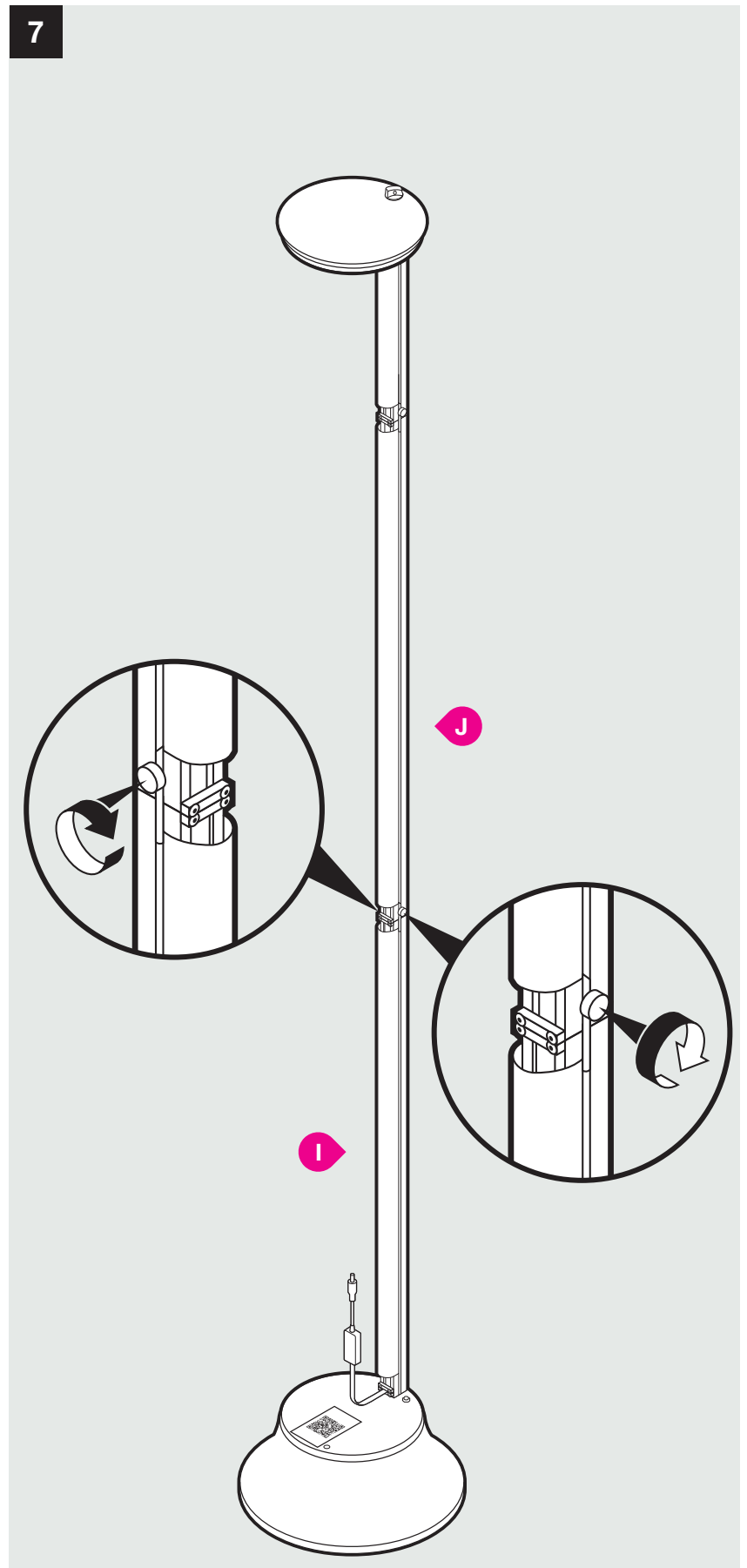
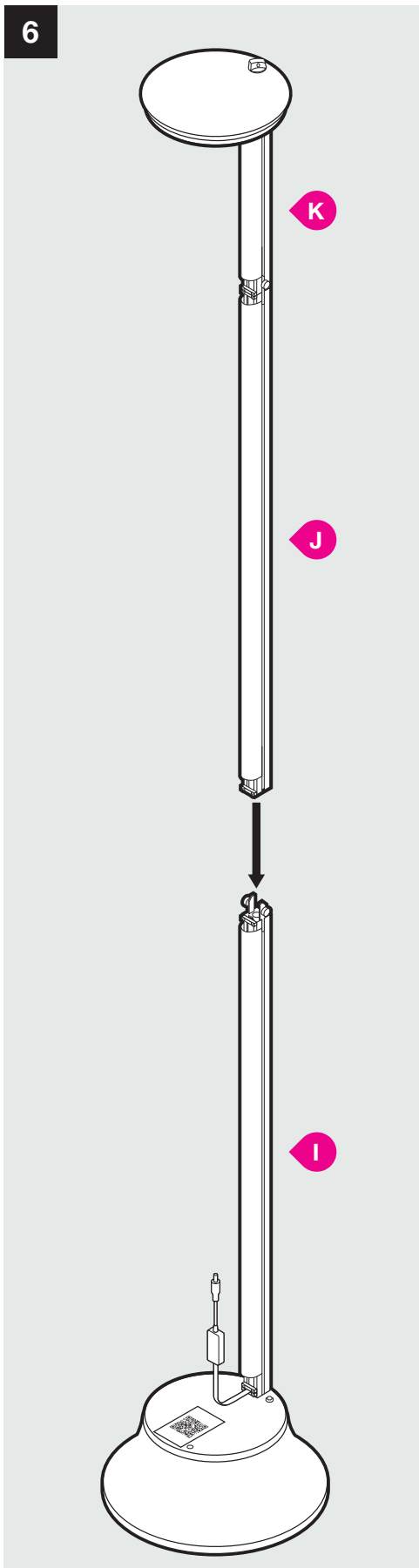

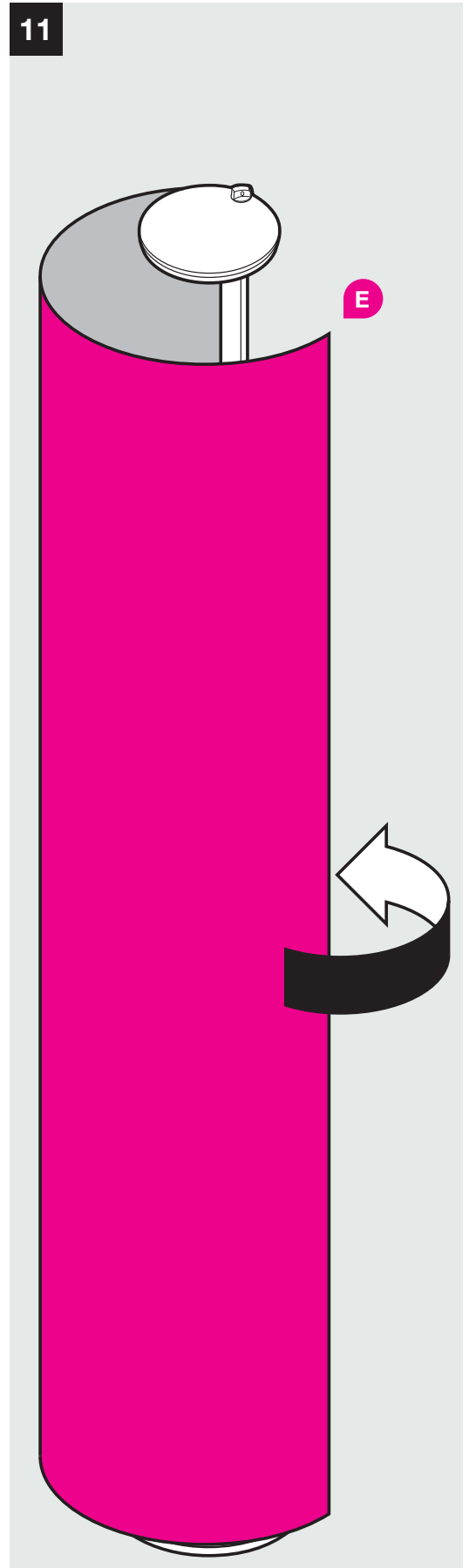
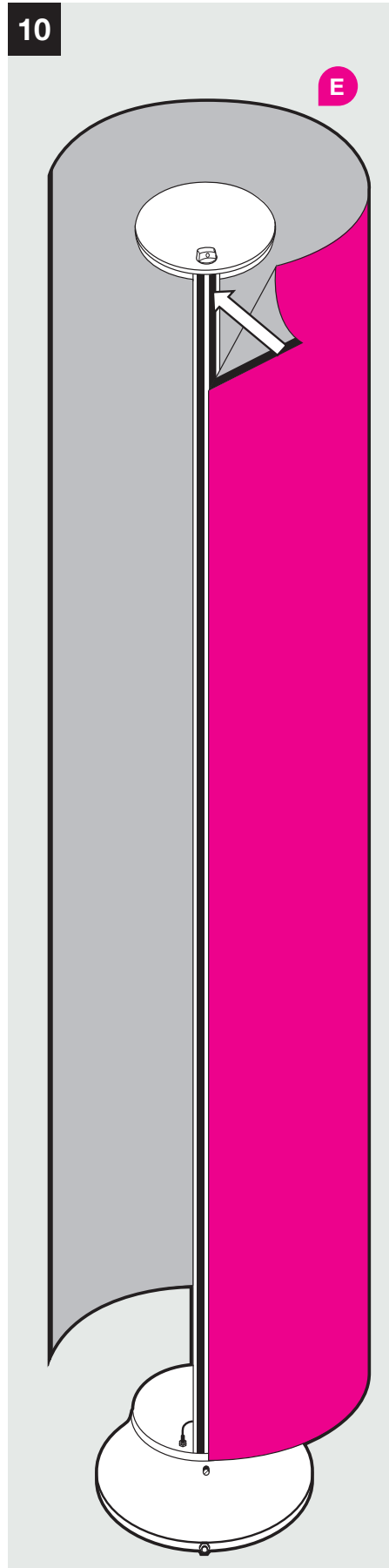
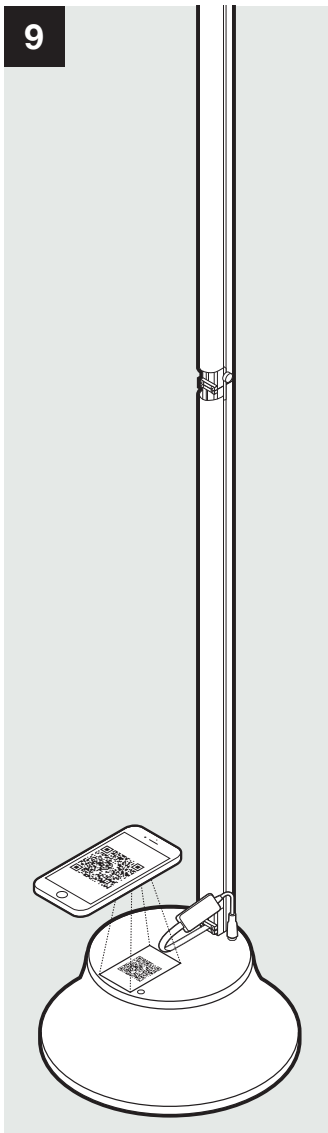
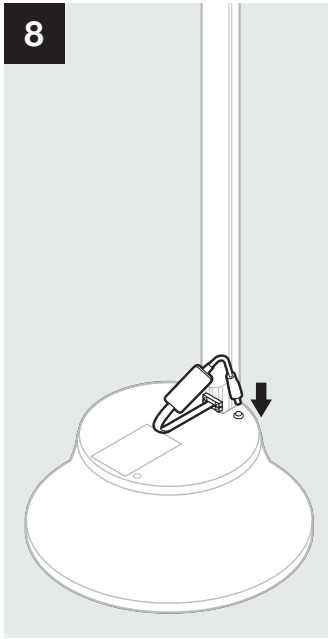

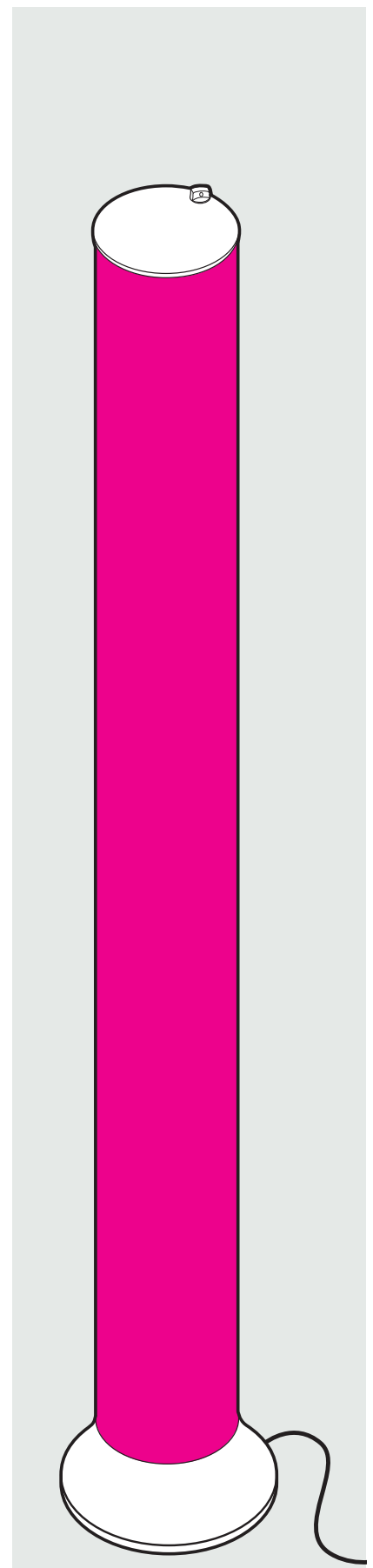
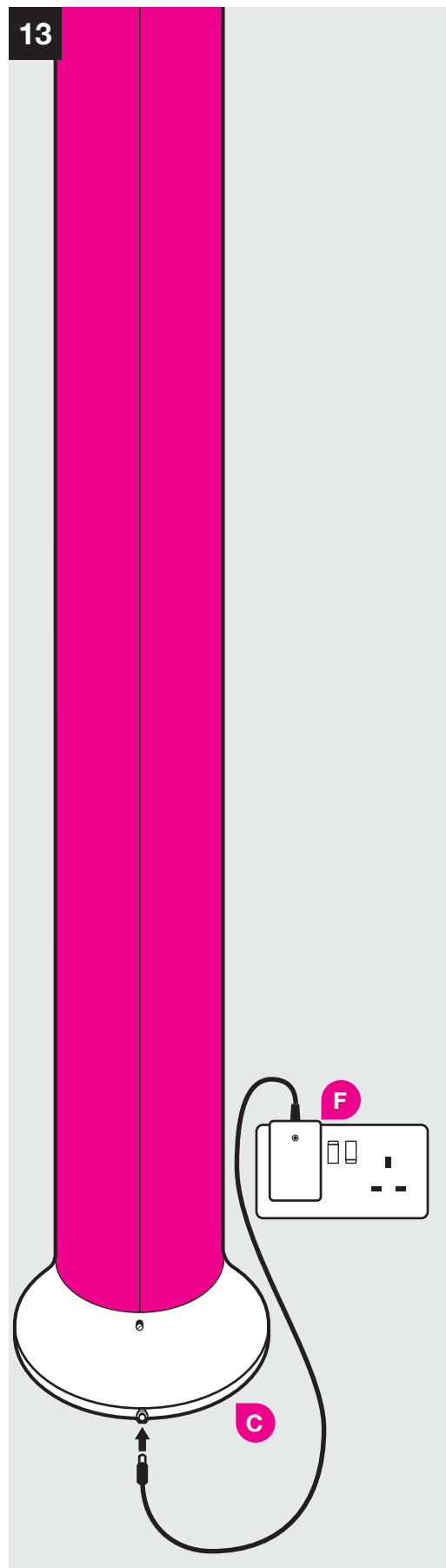
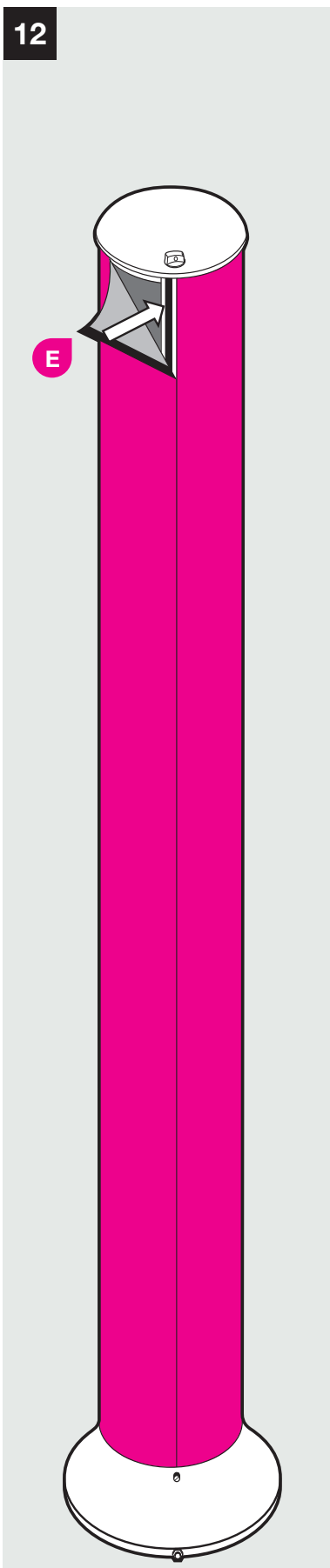

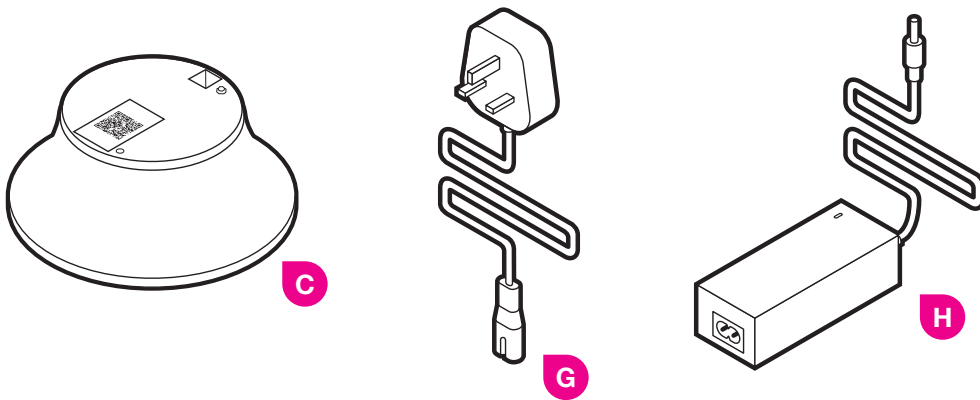



 This product contains a non-spillable lead-acid battery. Please dispose of responsibly. Contact your local authorities for more information.

