

iPad Apollo

Assembly Instructions



iPad Counter Mount

1

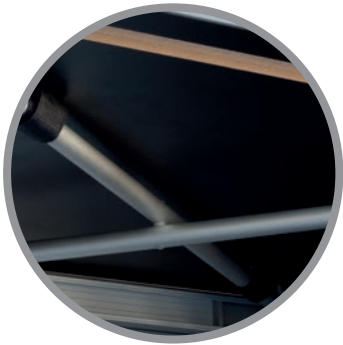

Select desired position for iPad display, ensuring that the fixings for the underside of the counter top will not interfere with any framework. Using the template provided, mark the hole centres using a centre punch or similar. Carefully drill 4 clearance holes through counter top, suitable for M6 screw threads.

Please note:

You will require a drill, M6 wood bit, pilot hole bit, and 20mm flat wood bit for complete assembly.

See back page for hole template.

2

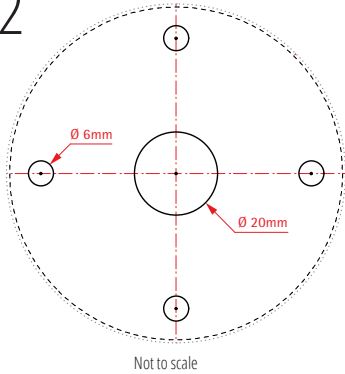

If you require cable management for charging, please punch centre of 20mm diameter hole. Drill pilot hole first to ensure it remains central to outer 4 fixing holes. Finally, bore a hole of approximately 20mm in diameter to allow USB end of charge/sync cable to pass through.

3



Align first 2 holes of the iPad holder to drilled holes and insert 2 off fixing screws.

4

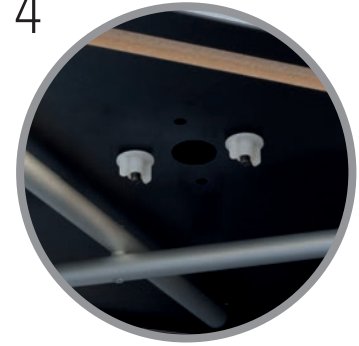

Position wing nuts over protruding screw threads on the underside of the counter top and tighten to secure assembly.

5

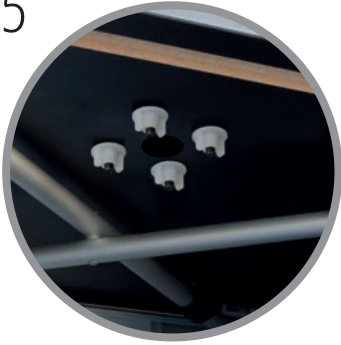

Rotate iPad holder through 90°, aligning remaining 2 holes. Insert screws and secure using wing nuts as before.

6



Unlock the iPad enclosure by inserting key into security lock and rotate 'QUARTER TURN ONLY' clockwise or counter-clockwise through 90 degrees which releases the locking pin. Return key back to original position to remove.

7



Lift fascia out of enclosure. Gently press cable (supplied with Apple iPad) into retaining moulding, allowing 10cm to remain "free" at charge/sync connector end.

8



Feed USB end of charge/sync cable through middle of enclosure, below pin, so it protrudes from underside of counter/table top.



For power extension to your iPad Counter Mount, plug figure-8 head of power lead supplied, into USB power adapter (supplied with Apple iPad).

9



Plug charge/sync cable into iPad and place inside enclosure, gently press all four corners of iPad down into mouldings to hold.



N.B. If you are not using cable management for charging, unlock the iPad enclosure by inserting key into security lock and rotate 'QUARTER TURN ONLY' clockwise or counter-clockwise through 90 degrees which releases the locking pin. Return key back to original position to remove. Lift fascia out of enclosure, and place iPad inside, gently pressing all four corners down into mouldings to hold.

10



Replace fascia and depress lock button to secure enclosure.



Template for holes

